

Wind Energy

Silverton CCC



Scott Lauder
Wind Energy Operations Manager

September 2012



Agenda

- > **Status of Wind Energy In Australia / South Australia**
- > **Wind Turbine Technology**
- > **Development of Wind Farms**
- > **Question & Answer**

Status of Wind Energy in South Australia and Australia



State of Play - Australia

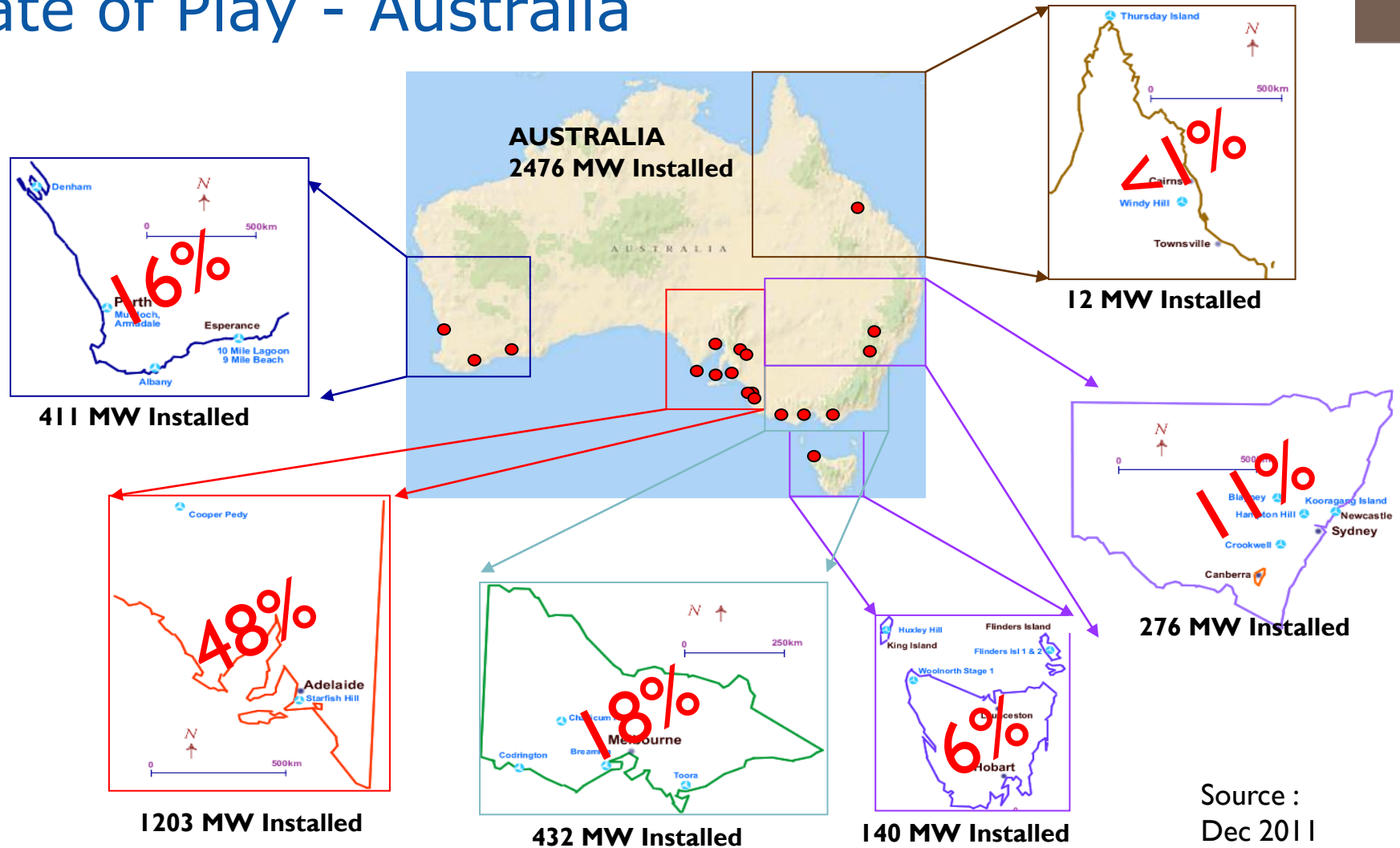

Source :
Dec 2011
Dave Clarke

- » Wind Energy
- » September 2012
- » Silverton CCC



Wind Energy Projects in S.A.

Wind farms currently generate about 20% of the state's electricity.

Compare to:

Denmark 20%

Spain 9%

Germany 7%

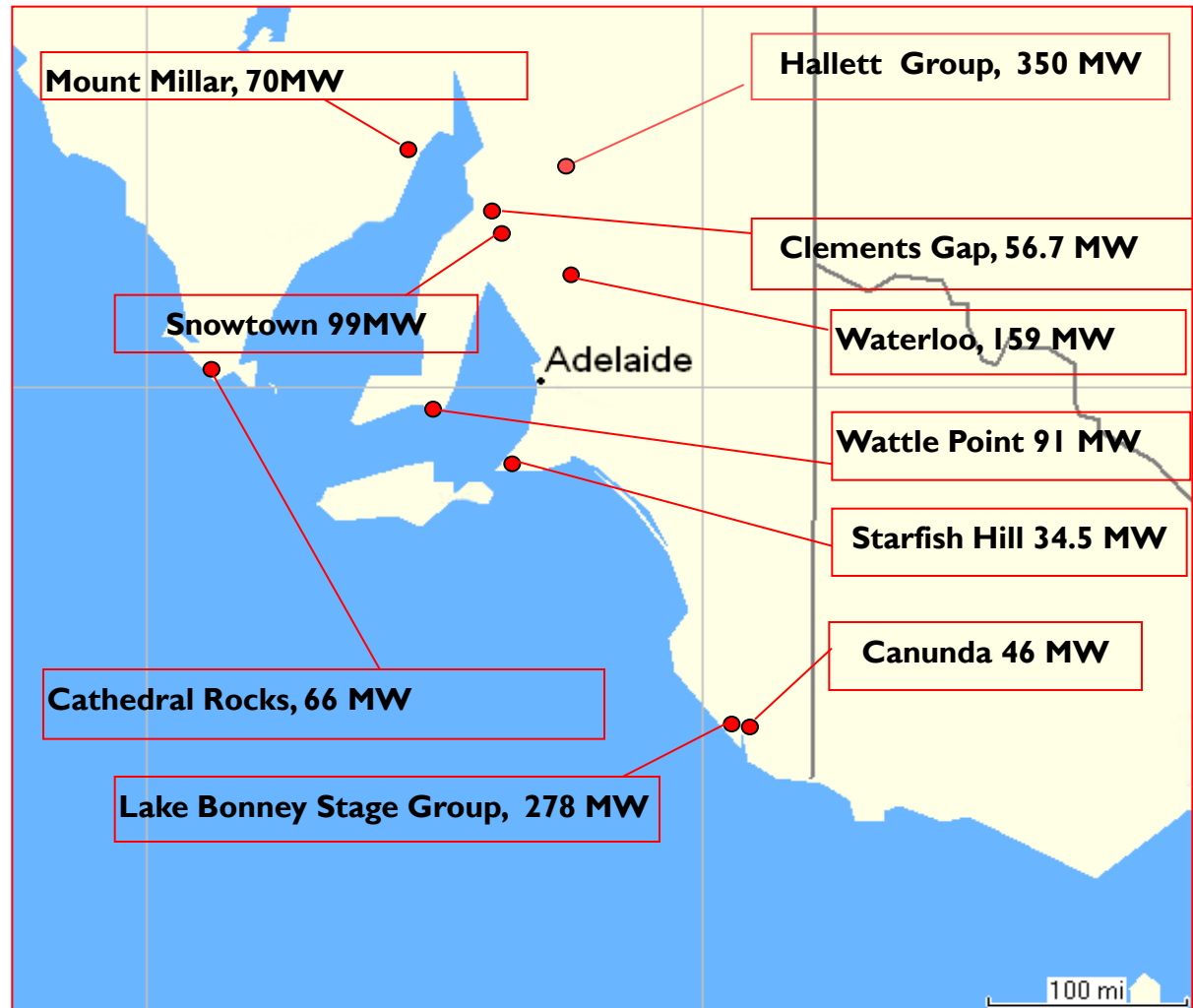

- » **Wind Energy**
- » September 2012
- » Silverton CCC

AGL Wind Farms in the Mid-North

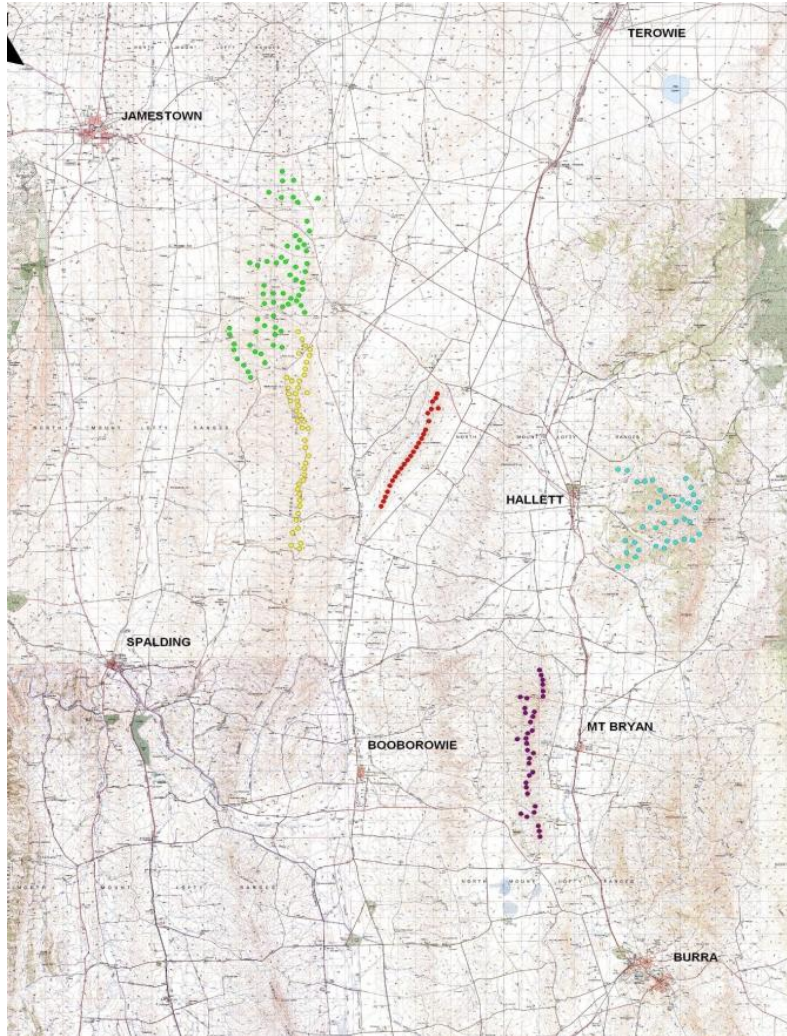

H1 – 45 turbines operational (yellow)

H2 – 34 turbines operational (purple)

H4 – 63 turbines operational (green)

H5 – 25 turbines operational (red)

- » **Wind Energy**
- » September 2012
- » Silverton CCC

Impact on GG Emissions in SA

- SA's coal and gas generation have reduced 2007-2011 while wind generation increased
- SA's Renewable energy penetration (virtually all wind) during 2011 was 20% and rising
- SA's GG emissions decreased 6% from 2007 to 2008, and a further 8% from 2008 to 2009, a total of 13.4% over 2 years. The trend shows a decline in emissions over the last few years predominantly due to increased wind generation

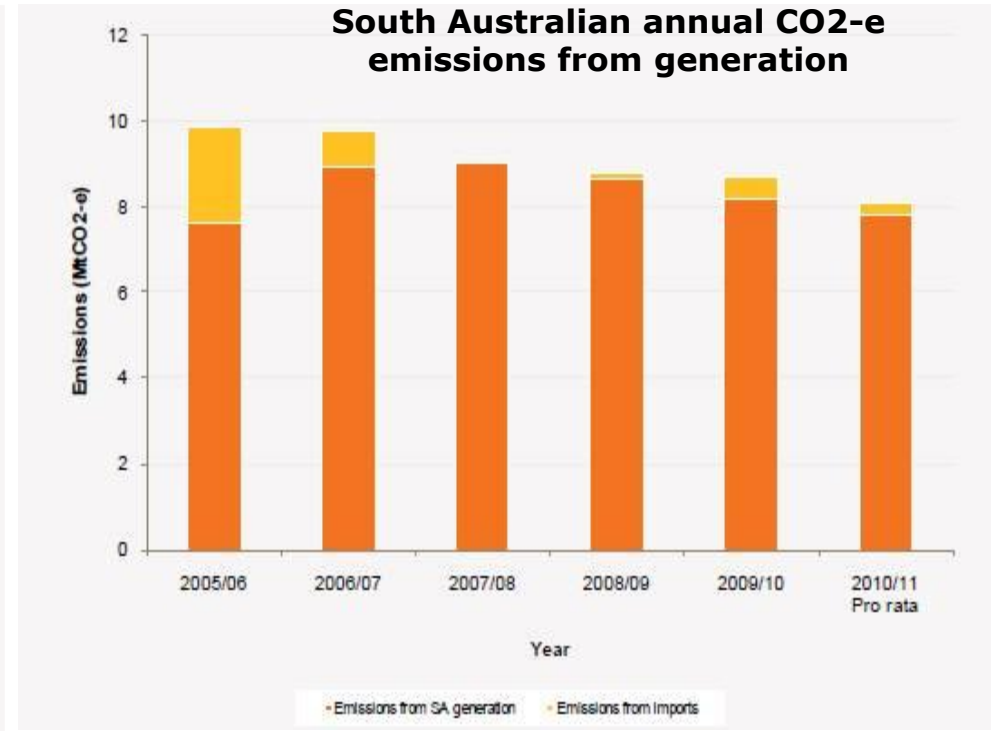
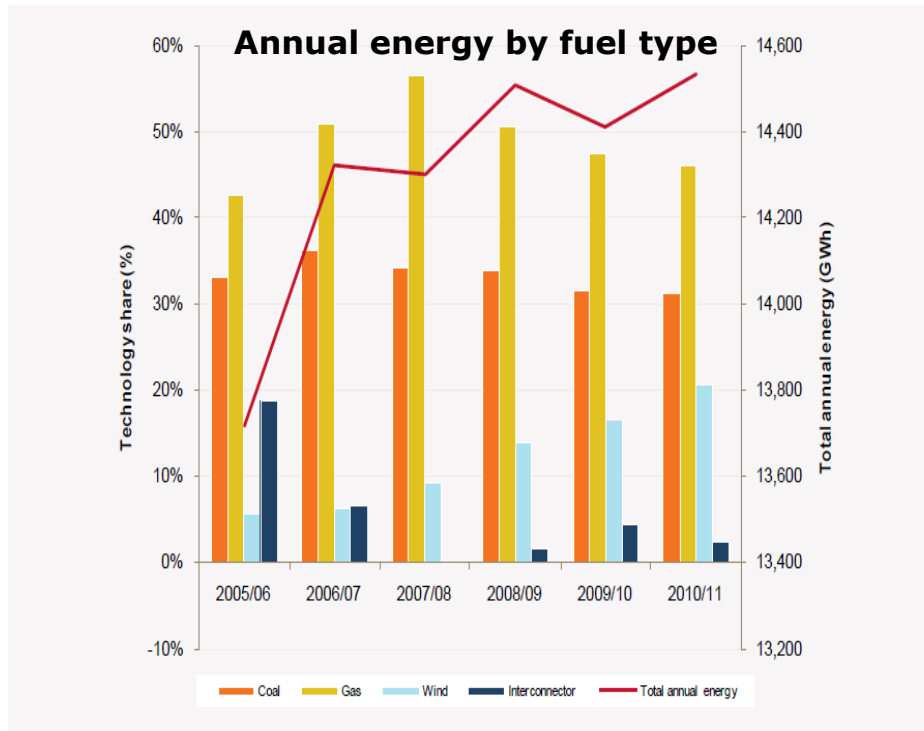

- » **Wind Energy**
- » September 2012
- » Silverton CCC

Wind Turbine Technology



Modern Wind Turbines

HAWT technology developed in Denmark and Germany about 20 years ago

20-25 year operating life

Pay back the energy used to make them within 3-6 months

Machines have continued to increase in size

A 2.0MW machine will produce enough energy for 1200 homes

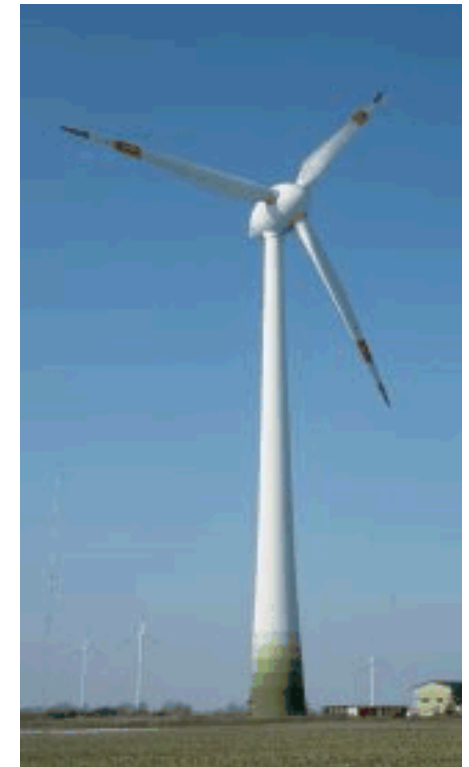
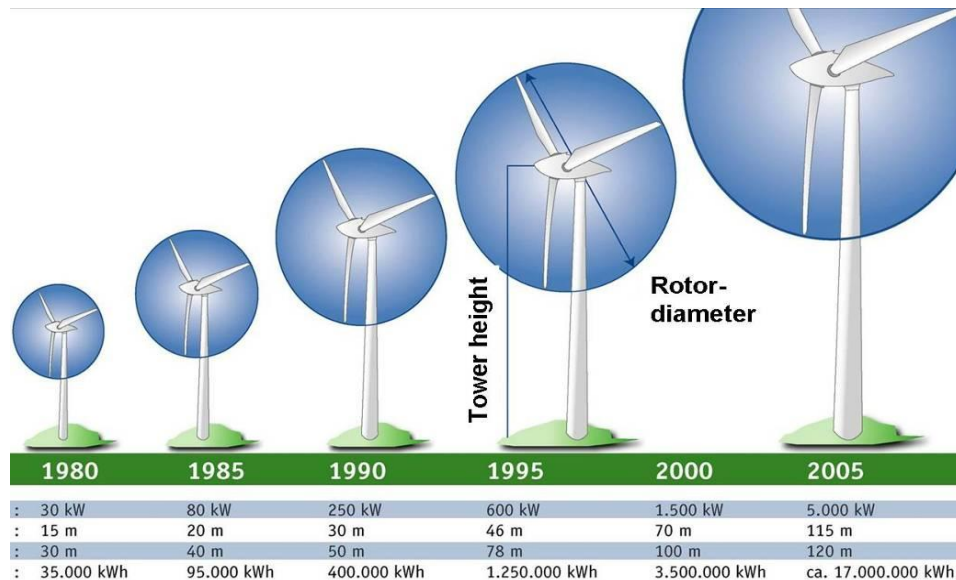

- » **Wind Energy**
- » September 2012
- » Silverton CCC

Inside A Modern Wind Turbine

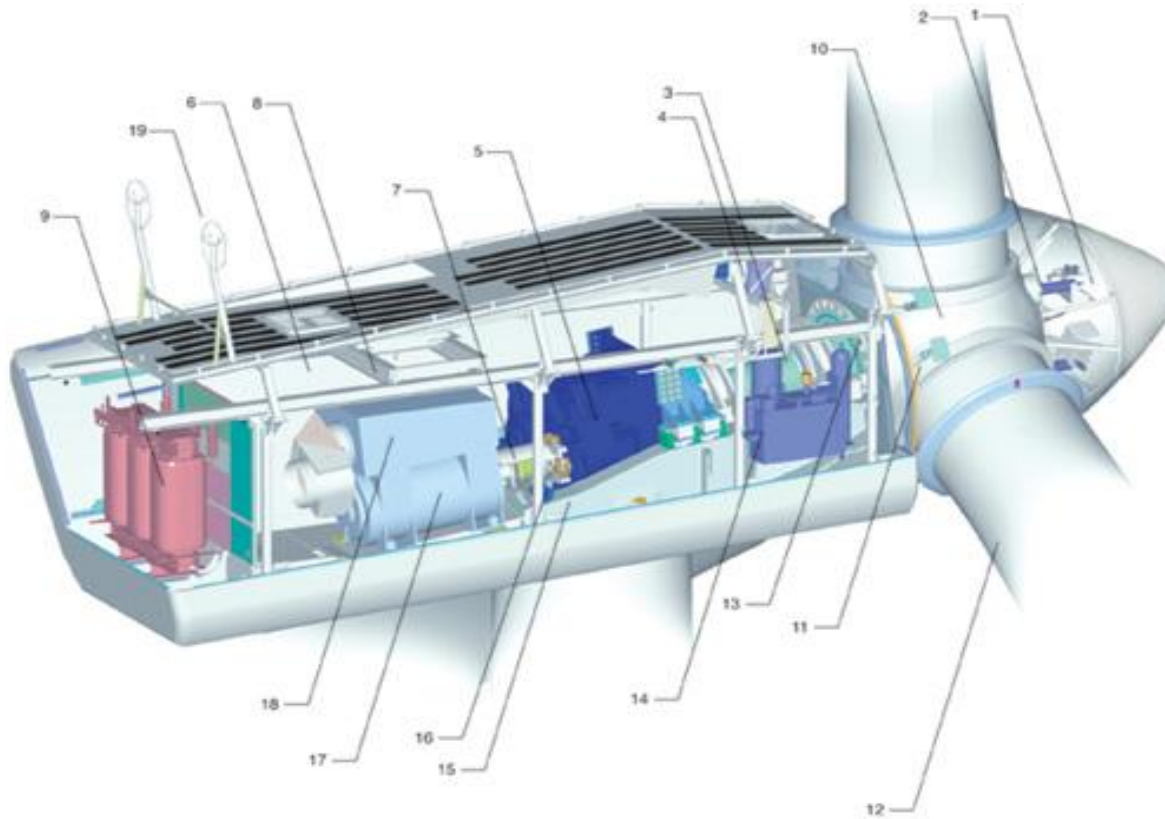

1. Hub controller
2. Pitch cylinder
3. Main shaft
4. Oil cooler
5. Gearbox
6. VMP-Top controller
7. Parking break
8. Service crane
9. Transformer
10. Blade hub
11. Blade bearing
12. Blade
13. Rotor lock system
14. Hydraulic unit
15. Machine foundation
16. Yaw gears
17. Generator
18. Ultra-sonic sensors

How Much Does Wind Energy Cost?

Currently about 2 times the cost of coal & gas generation.

Wind energy costs are reducing about 2-4% per year.

Fossil fuel generators are currently not accountable for the pollution they create.

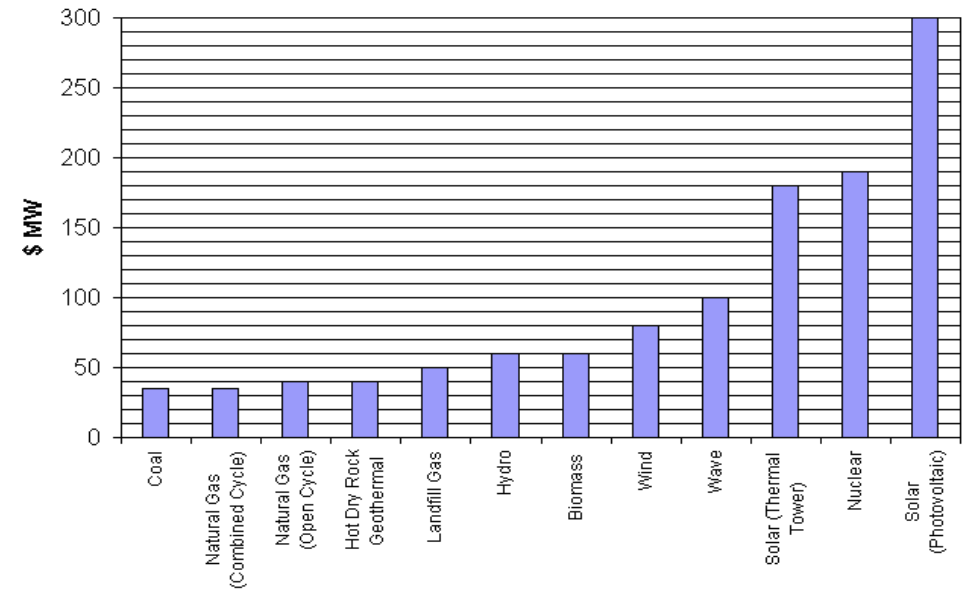
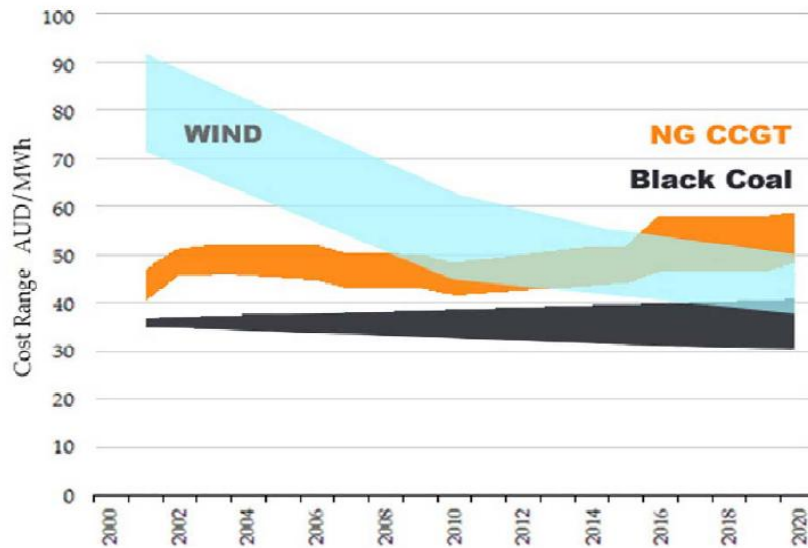

- » **Wind Energy**
- » September 2012
- » Silverton CCC

Source :AusWIND



Wind Farm Development



Development of a Wind Farm

Landowner Agreements

Layouts (wind farm – turbines, access, cabling, interconnection)

Wind Monitoring

Public and Stakeholder Consultation

Ecology (State and Federal)

Aboriginal Heritage

Noise Studies

CASA / RAAF

Development Approval and other authorisations

Grid Connection

Wind Farm – Benefits to Communities

- Diversified, reliable income for landowners
- Employment opportunities (construction & operations)
- Opportunity for local towns to provide products and services
- More robust and diversified economy (eg Maintenance Facility)
- Community funds
- Sponsorships (eg Suzlon – Bundaleer Festival, AGL – Bush to Burra)
- Potential for tourism (eg Burra Info Centre)
- Mitigation of the effects of climate change

Resources

www.windpower.org/en Wind With Miller (and follow links)

www.cleanenergycouncil.org.au Clean Energy Council

www.agl.com.au/hallett5 AGL's Hallett Stage 5 Wind farm

www.ramblingsdc.net/Australia/WindPower.html Dave Clarke's Site

www.yes2renewables.org Yes to Renewables

www.awea.org American Wind Energy Association

www.bwea.com RenewableUK

www.ewea.org European Wind Energy Association

www.windfarmperformance.info Wind Farm Performance in Australia

www.windturbinesyndrome.com Website of the book

www.climatechange.gov.au Department of Climate Change

-
- » **Wind Energy**
 - » September 2012
 - » Silverton CCC

